

PRODUCT SPECIFICATION 产品规格书

NM17001N-LM

70cm Round Mirror With LED, Magnifier

70公分 LED带放大镜圆型镜



(Rough-in Dimensions):

安装尺寸图:

(Unit): mm

单位: 毫米

Size: $\varnothing 700 \times 30$ mm

尺寸: $\varnothing 700 \times 30$ mm

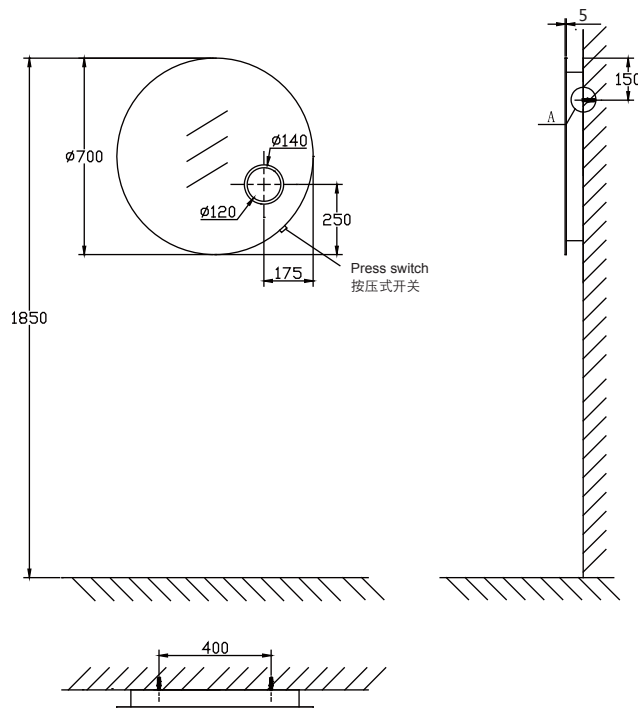
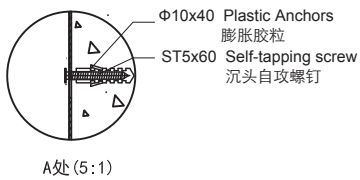

Item No. 品号	NM17001N-LM
Available Color 颜色	White Frame 白色边框
Materials 材质	5mm The mirror, Aluminum 5mm 镜子, 铝合金方管
Shipping Package 运输包装	CTN/Set: 1 CTN M ³ /CTN: 0.053 M ³ G.W/CTN: 10.6 kg 箱/套: 1 箱 体积/箱: 0.053 M ³ 毛重/箱: 10.6 kg
Hardware Accessories (hinge) 五金配件(铰链)	There is no 无
Certification is introduced 认证介绍 (电器)	CE and IP44 certification CE和IP44认证
Function is introduced 功能介绍	LED function A magnifying glass Anti-fog mirror LED功能 放大镜功能 防雾镜
Remarks: White light, Voltage: AC220V; Frequency: 50HZ. Press switch 备注: 白光光源, 电压: AC220V, 频率: 50HZ. 按压开关	

INNOCI reserves the right to make changes or modifications on any of its products without advance notice.
INNOCI 艺耐公司保留不事先通知便改变或修改的权利

innoci[®]

Innoci Sanitary ware Co., Ltd
www.innoci.com

Version : A0
版次 : A0